

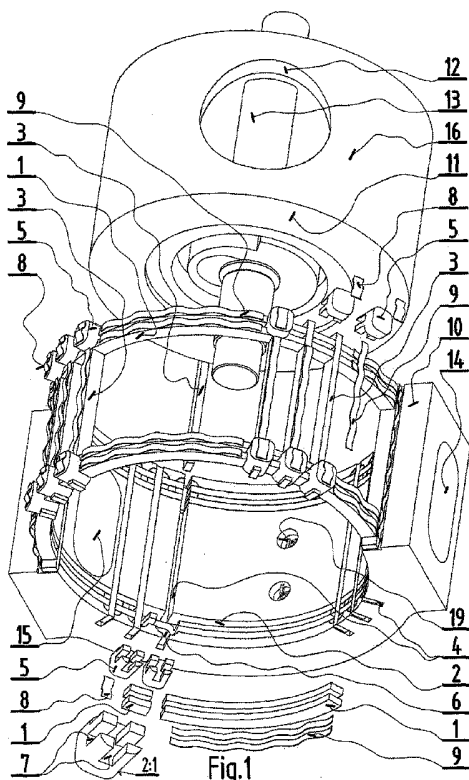

- (51) International Patent Classification:
F01B 13/06 (2006.01) F02F 11/00 (2006.01)
F02B 57/08 (2006.01)
- (21) International Application Number: PCT/CZ2013/000077
- (22) International Filing Date: 17 June 2013 (17.06.2013)
- (25) Filing Language: English
- (26) Publication Language: English
- (30) Priority Data: PV 2012-422 21 June 2012 (21.06.2012) CZ
- (71) Applicant (for all designated States except US): **KNOB ENGINES S.R.O.** [CZ/CZ]; Za Kajetánkou 1271/32, 16900 Praha 6 (CZ).
- (72) Inventor: **KNOB, Václav**; Za Kajetánkou 1271/32, 16900 Praha 6 (CZ).
- (74) Agent: **KRATOCHVÍL, Václav**; P.O.Box 26, 29501 Mnichovo Hradiště (CZ).
- (81) Designated States (unless otherwise indicated, for every kind of national protection available): AE, AG, AL, AM, AO, AT, AU, AZ, BA, BB, BG, BH, BN, BR, BW, BY, BZ, CA, CH, CL, CN, CO, CR, CU, CZ, DE, DK, DM, DO, DZ, EC, EE, EG, ES, FI, GB, GD, GE, GH, GM, GT, HN, HR, HU, ID, IL, IN, IS, JP, KE, KG, KN, KP, KR, KZ, LA, LC, LK, LR, LS, LT, LU, LY, MA, MD, ME, MG, MK, MN, MW, MX, MY, MZ, NA, NG, NI, NO, NZ, OM, PA, PE, PG, PH, PL, PT, QA, RO, RS, RU, RW, SC, SD, SE, SG, SK, SL, SM, ST, SV, SY, TH, TJ, TM, TN, TR, TT, TZ, UA, UG, US, UZ, VC, VN, ZA, ZM, ZW.
- (84) Designated States (unless otherwise indicated, for every kind of regional protection available): ARIPO (BW, GH, GM, KE, LR, LS, MW, MZ, NA, RW, SD, SL, SZ, TZ, UG, ZM, ZW), Eurasian (AM, AZ, BY, KG, KZ, RU, TJ, TM), European (AL, AT, BE, BG, CH, CY, CZ, DE, DK, EE, ES, FI, FR, GB, GR, HR, HU, IE, IS, IT, LT, LU, LV, MC, MK, MT, NL, NO, PL, PT, RO, RS, SE, SI, SK, SM, TR), OAPI (BF, BJ, CF, CG, CI, CM, GA, GN, GQ, GW, KM, ML, MR, NE, SN, TD, TG).

[Continued on next page]

(54) Title: SEAL ASSEMBLY FOR ROTARY PISTON INTERNAL COMBUSTION ENGINE



(57) Abstract: The invention relates to seal assembly for a rotary piston internal combustion engine comprising a rotating block (11) of a rotational shape with radially situated cylinders (12) with pistons (13) and an outer stationary case (10) with at least one intake port (14) and/or exhaust port (15). The outer surface (16) of the rotating block (11) is a rotational surface with a straight line or curved profile curve, on which transverse and/or side sealing parts, which are placed in the stationary case (10), sit. In circular side grooves (2) there is a side seal consisting of circular side sealing segments (1) that are always placed between neighbouring transverse sealing strips (3), which are placed in transverse grooves (4). Those sealing strips (3) go through the side grooves (2) across. In the place, where the side sealing segments (1) and transverse sealing strips (3) meet, there are joints (5) with notches (7) for inserting the side sealing segments (1) and transverse sealing strips (3).

WO 2013/189471 A1



Published:

— with international search report (Art. 21(3))

— before the expiration of the time limit for amending the claims and to be republished in the event of receipt of amendments (Rule 48.2(h))

Seal Assembly for Rotary Piston Internal Combustion EngineTechnical Field

The invention relates to embodiment of seal for an internal combustion engine that comprises a rotating block of a rotational shape, with radially situated cylinders with pistons. Outside the rotating cylinder block there is a stationary case with at least one intake and/or exhaust port. The rotating cylinder block together with the stationary case work like a rotary valve.

10 Background of the invention

There have been designed many engines with a rotating block of a rotational shape with radially situated cylinders with pistons and an outer stationary case with an intake and/or exhaust port. The rotating cylinder block together with the stationary case work like a rotary valve. There are well known designs of two-stroke as well as four-stroke engines, two, three and multi-cylinder arrangements. Some engines have been equipped with the crankshaft mechanism and some have been equipped with other known mechanisms for transferring the motion of the piston to the shaft. None of those designs has achieved wider enlargement and utilization despite the undoubted potential.

There are many reasons why these engines were not successful. The main reason is that the seal between the rotating block and the stationary case was not optimally designed. Mostly, the seal between cylinder space and the stationary case was done by means of sealing elements that were placed in the rotating cylinder block. Those sealing elements were then exposed to centrifugal forces that result from rotation of the rotating block. Together with increasing revolutions that leads to significant stress of these sealing elements, to high friction losses and lubrication problems.

Such designs are described e. g. in documents DE 2732779, FR2767156A1.

There have been also designs with a seal that is placed in the stationary case of the engine. The most simple is a seal
5 in the form of rings that are placed on both sides of the perimeter of the rotating block. Another seal is done by transverse sealing strips that are placed in the stationary case in the transverse direction with respect to the motion of the perimeter of the rotating block. Such designs are
10 described e. g. in documents FR2639676A1, US1705130A, WO9823850A1, WO8302642A1, etc. This solution is advantageous due to absence of centrifugal forces that act on the sealing parts. Due to minimizing volume of interstices in the combustion space it is necessary to place the side sealing
15 rings as close to cylinder bores as possible. If the side sealing parts are too close to the cylinder bore, then the transverse sealing strips extend too little beyond the cylinder bore, when these cylinder bores are passing these sealing strips. That would increase wear and decrease
20 tightness and durability of the sealing strips. Due to the total length of the seal of the space with high pressure it is necessary to achieve as perfect sealing as possible. Untightness in the place, where the sealing strips and rings meet, is a problem. Gas can blow by through both clearance
25 between sealing parts and particularly at the bottom of their connected grooves. If there is more than one side sealing ring, gas that overcomes the first ring can further blow through the circumferential interstice between side rings.

Summary of the invention

30 Above mentioned deficiencies are removed to a large extent by seal assembly for the rotary piston internal combustion engine comprising a rotating block of a rotational shape with radially situated cylinders with pistons and an outer

stationary case with at least one intake port and/or exhaust port, while the outer surface of the rotating block is a rotational surface with a straight line profile curve or a curved line profile curve, on which the transverse and/or side seals, which are placed in the stationary case, sit down, according to this invention. The essence is that in the circular side grooves there is a side seal that consists of circular side sealing segments that are always located between neighbouring transverse sealing strips that are placed in transverse grooves. Those sealing strips go through the side grooves across. In the place where the side sealing segments and transverse sealing strips meet there are joints with notches for inserting the side sealing segments and transverse sealing strips.

Those joints are advantageously placed in bores in the outer stationary case. The cross-section of the joints is in the shape of an n-polyhedron, where n ranges between 3 and ∞ , i. e. the cross-section can be in the shape of a polyhedron, circle or oval, etc. There are springs between the joints and the stationary case. The joints simultaneously sit down to side sealing segments and/or transverse sealing strips by their bottom of notches and that ensures pressing these seals down to the surface of the rotating block. Side sealing segments and/or transverse sealing strips are advantageously equipped with more springs that are placed in the side grooves and/or transverse grooves in the stationary case.

Side sealing segments are advantageously in at least two rows next to each other in at least two side grooves, while the nearest row of the side sealing segments is placed in close proximity of cylinder bores that are in the rotating block.

The joint is advantageously placed in the place, where at least one transverse strip and at least two side sealing segments meet.

5 The transverse sealing strip has advantageously a chamfer on the seating surface. That chamfer is oriented in the way that it is on the opposite side of the spark plug.

10 Seal assembly for the rotary piston internal combustion engine enables effective sealing between the rotating block and the stationary case. Placement of the sealing elements in the stationary case ensures that the pressure force of the sealing elements is independent on the engine speed and that allows reaching high engine speed and thus high specific parameters. All transverse sealing strips and side sealing segments have a planar contact with the rotational outer surface of the rotating block. That decreases demands on the sealing elements material and quality of the outer surface area of the rotating block. Planar contact of the sealing elements also decreases demands on lubrication of sealing elements and increases their efficiency and durability. The main advantage is that the transverse sealing strips can be long and extend sufficiently on both sides over the widest point of the cylinder bore in the rotating block, when the cylinder bore passes the transverse strip. At the same time it is possible to place side sealing segments close to cylinder bores in the rotating block and thus minimize the space of interstice between the rotating block and stationary case. Sealing the space with high cylinder pressure between the rotating block and the stationary case can be done by multiple seals in both transverse and side direction, which ensures high level of sealing.

15
20
25
30

Sealing joints are also important, because they ensure seal of clearances between transverse sealing strips and side sealing segments. If the joint sits down on the transverse

sealing strip or on the side sealing segment by its bottom of notches, so it closes the clearance at the bottom of the notch and prevents gas blowing through clearances at the bottom of the transverse groove and side groove.

5 Suitable shape of the transverse strip profile can utilize cylinder pressure to increase pressure force that presses the strip to the rotating block. When the cylinder pressure decreases or when the cylinder bore passes the transverse strip, load of the transverse sealing strip is reduced, which
10 leads to lower friction losses and wear.

 Joints can be seated in bores in the outer stationary case and those bores are easy to manufacture in any phase of engine manufacturing. The joints can have various cross-sectional shapes, from a triangle to a circle. Springs between joints
15 and the stationary case ensure sufficient pressure force that presses the sealing segments and/or transverse sealing strips to the outer surface of the rotating block. The pressure force is created also by other springs. The chamfer on the transverse sealing strip is oriented in the way that it is on
20 the opposite side of the spark plug. That ensures better seating and guiding of the sealing strip.

 Using this seal assembly in a rotary piston internal combustion engine enables realization of a simple, production-cheap engine of small dimensions, with small number of moving
25 parts, with balanced, silent working and high specific parameters.

Brief description of the drawings

 Seal assembly for a rotary piston internal combustion engine according to the invention will be closer clarified on
30 model embodiment by means of enclosed drawings. In the figure 1 there is an axonometric view of the seal assembly with a half of the stationary case and the rotating block with

cylinders and pistons. The cylinder block with pistons is axially moved from the outer stationary case for better illustration.

5 Figure 2 is an unfolded view of the inner surface of the stationary case and also a cross-sectional view of the rotating block taken longitudinally through the axis of rotation.

10 Figure 3 schematically shows a cross-sectional view of the rotary piston engine taken perpendicularly to the axis of rotation, where the transverse sealing strips with chamfers are pictured.

Detailed description of the invention

15 Model seal for a rotary piston internal combustion engine according to the figure 1 comprises circular side sealing segments 1, transverse sealing strips 3, joints 5, springs 8 and other springs 9. All these parts are placed in a stationary case 10, in which a rotating block 11 with radially situated cylinders 12 and pistons 13 is placed. Its outer
20 surface 16 is a rotational cylindrical surface. The stationary case 10 is provided with an intake port 14 and exhaust port 15. Side sealing segments 1 are placed in two rows in circular side grooves 2. Springs 8 and joints 5 are placed in bores 6. Transverse sealing strips 3 are placed in transverse grooves 4
25 and other springs 9 are placed in transverse grooves 4 and side grooves 2. Between the spark plug 19 and both the intake port 14 and exhaust port 15 there are three transverse strips 3. Joints 5 are provided with notches 7, which side sealing segments 1 and transverse sealing strips 3 reach. The joint 5
30 connects always one transverse sealing strip 3 and four side sealing segments 1.

Embodiment of seal assembly for a rotary piston internal combustion engine according to figure 2 follows the embodiment according to figure 1. The difference is in use of different joints 5. They have different shapes and forms of the notches 7. Some connect one transverse strip 3 with four side sealing segments 1. Some connect one transverse strip 3 with only two side sealing segments 1 and some connect two transverse strips 3 with four side sealing segments 1.

Embodiment of seal assembly for a rotary piston internal combustion engine according to figure 3 follows the embodiment according to figure 1. Transverse sealing strips 3 have a chamfer 17 on their seating surface 18. The chamfer is oriented in the way that it is on the opposite side of the spark plug 19.

The function of seal assembly for a rotary piston internal combustion engine is following. Springs 8 press joints 5 to the outer surface 16 of the rotating block 11. The joints 5 can sit down onto side sealing segments 1 and/or onto transverse sealing strips 3 by bottoms of their notches 7. The pressure force of springs 8 is then transferred also on the side sealing segments 1 and/or on transverse sealing strips 3 and they are pressed to the outer surface 16 of the rotating block 11. Side sealing segments 1 and/or transverse sealing strips 3 can be also pressed to the outer surface 16 of the rotating block 11 by other springs 9. As the rotating block 11 rotates in the stationary case 10, the cylinder bore 12 stepwise passes all transverse sealing strips 3, which extend the cylinder bore 12 sufficiently on both sides and there is no danger in their damage. At the ignition time there are advantageously more transverse strips 3 between the cylinder bore 12 and the intake port 14 and/or exhaust port 15. They ensure fine sealing of the cylinder space 12. Sealing is also improved by placing the side sealing segments 1 in more rows

next to each other. Joints 5 can connect more side sealing segments 1 with one or more transverse strips 3. Transverse strips 3 can have a chamfer 17 on the seating surface 18, which is oriented in the way that it is on the opposite side of spark plugs 19. Cylinder pressure 12 creates then additional pressure force acting on transverse strips 3 and that further improves their tightness.

Industrial applicability

Seal assembly for a rotary internal combustion engine according to the invention can be used for instance in aircraft engines, motorcycle engines, racing car engines and other applications of rotary piston engines, where high performance at low weight and small dimensions are of high priority. Thanks to their simplicity and small dimensions, rotary piston engines equipped with seal assembly according to the invention can be also used as propulsion of garden equipment, standby generators, etc. Provided that the lubricating oil consumption is significantly limited it is possible to consider application in conventional vehicles, for instance as a range extender for electric vehicles.

PATENT CLAIMS

1. Seal assembly for a rotary piston internal combustion engine comprising a rotating block (11) of a rotational shape with radially situated cylinders (12) with pistons (13) and an outside placed stationary case (10) with at least one intake port (14) and/or exhaust port (15), while the outer surface (16) of the rotating block (11) is a rotational surface with a straight line or curved profile curve, on which transverse and/or side sealing parts, which are placed in the stationary case (10), sit, **characterized in that** in the circular side grooves (2) there is a side seal consisting of circular side sealing segments (1) that are always placed between neighbouring transverse sealing strips (3), which are placed in transverse grooves (4), and these sealing strips (3) go through the side grooves (2) across, while in the place, where the side sealing segments (1) and the transverse sealing strips (3) meet, there are joints (5) with notches (7) for inserting the side sealing segments (1) and transverse sealing strips (3).
2. Seal assembly for a rotary piston internal combustion engine according to claim 1 **characterized in that** the joints (5) are placed in bores (6) in the stationary perimeter case (10).
3. Seal assembly according to claims 1 or 2 **characterized in that** the joints (5) have a cross-section in the shape of an n-polyhedron, where n ranges between 3 and ∞ , and between joints (5) and the stationary case (10) there are springs (8), and the joints (5) simultaneously sit down to the side sealing segments (1) and/or transverse sealing strips (3) by their bottom of the notches (7) and that ensures pressing these seals down to the outer surface (16) of the rotating block (11).

4. Seal assembly according to claims 1, 2 or 3 **characterized in that** the side sealing segments (1) and/or transverse sealing strips (3) are equipped with other springs (9), which are placed in the side grooves (2) and/or in the transverse grooves (4) in the stationary case (10).
5
5. Seal assembly according to any of previous claims **characterized in that** the side sealing segments (1) are at least in two rows next to each other in at least two side grooves (2), while the nearest row of the sealing segments (1) is placed close to cylinder bores (12) in the rotating block (11).
10
6. Seal assembly according to any of previous claims **characterized in that** the joint (5) is placed in the place of connection of at least one transverse strip (3) and at least two side sealing segments (1).
15
7. Seal assembly according to any of previous claims **characterised in that** the transverse sealing strip (3) is provided with a chamfer (17) on the seating surface (18), which is oriented in that way that it is on the opposite side of the spark plug (19).
20

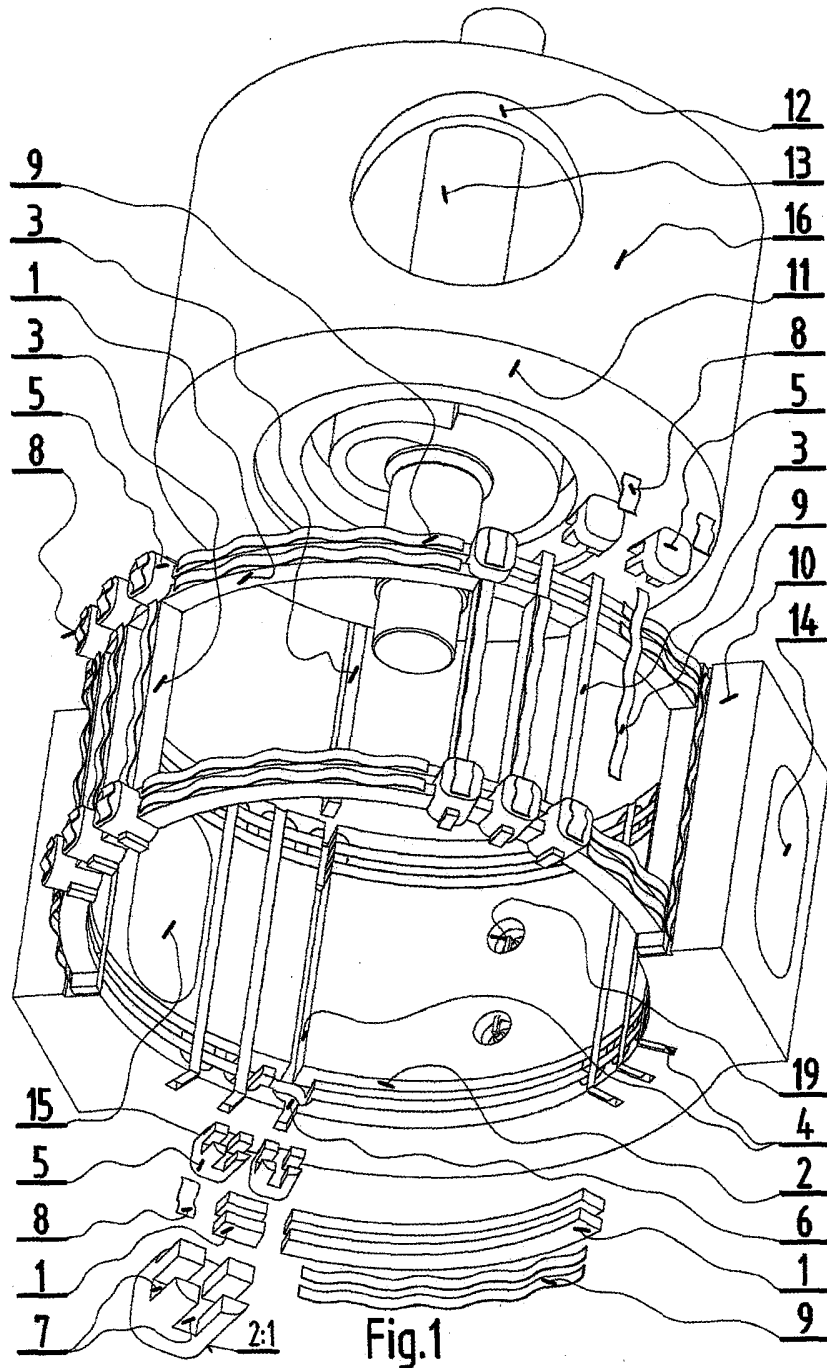

Fig.1

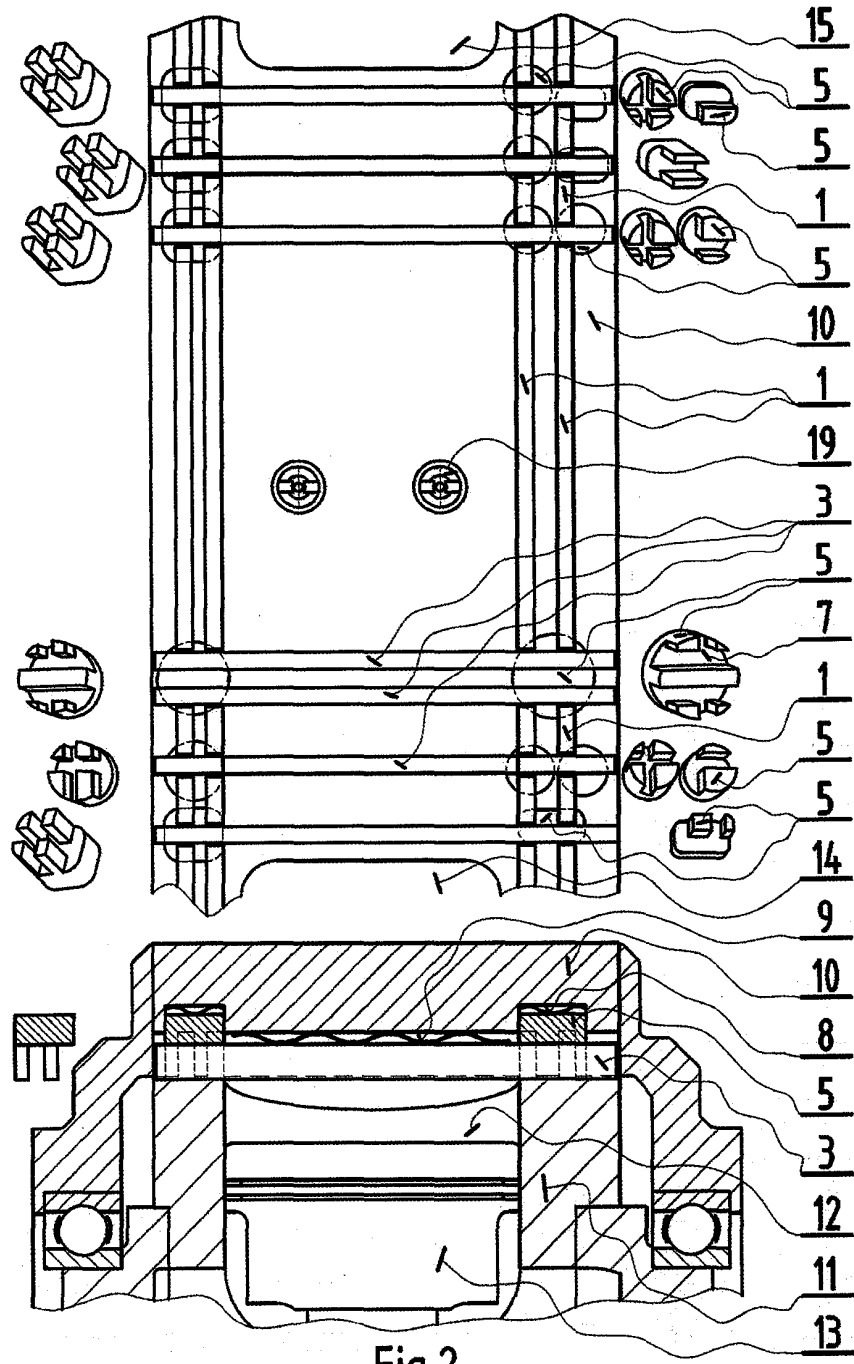

Fig.2

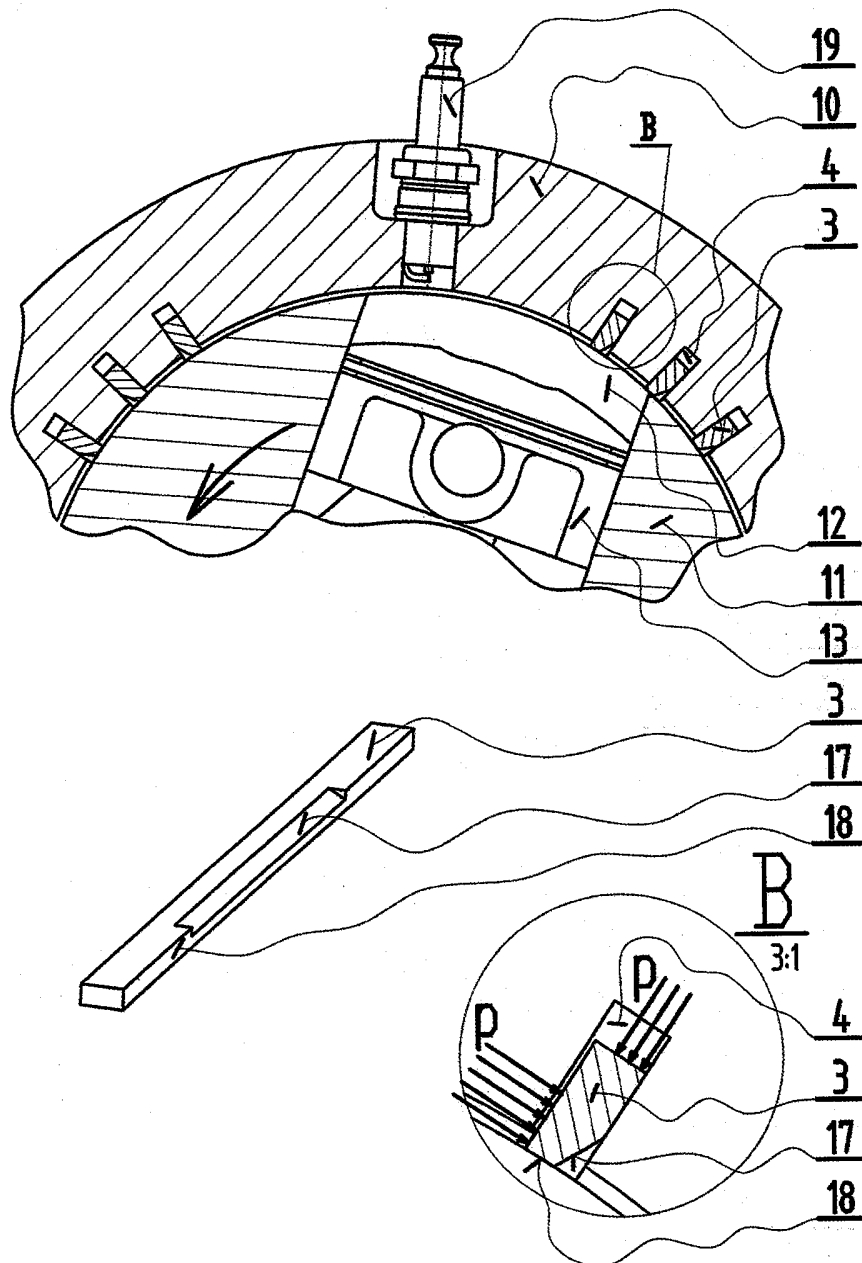

Fig.3

INTERNATIONAL SEARCH REPORT

International application No PCT/CZ2013/000077

A. CLASSIFICATION OF SUBJECT MATTER INV. F01B13/06 F02B57/08 F02F11/00 ADD.				
According to International Patent Classification (IPC) or to both national classification and IPC				
B. FIELDS SEARCHED				
Minimum documentation searched (classification system followed by classification symbols) F01B F02B F02F				
Documentation searched other than minimum documentation to the extent that such documents are included in the fields searched				
Electronic data base consulted during the international search (name of data base and, where practicable, search terms used) EPO-Internal, WPI Data				
C. DOCUMENTS CONSIDERED TO BE RELEVANT				
Category*	Citation of document, with indication, where appropriate, of the relevant passages	Relevant to claim No.		
A	US 2004/216703 A1 (WONDERGEM ANTHONY LEONARDUS [AU]) 4 November 2004 (2004-11-04) paragraph [0012] - paragraph [0013] -----	1		
A	US 6 928 965 B2 (TEUFL ERICH [DE]) 16 August 2005 (2005-08-16) column 9, line 61 - column 10, line 40 -----	1		
A	DE 34 17 342 A1 (FARKAS VLADIMIR [DE]; BOSER EKKEHART [DE]; KESSLER HELMUT [DE]) 21 November 1985 (1985-11-21) page 6, paragraph 1 -----	1		
A	WO 98/57036 A1 (CLIFFORD COLIN A [AU]) 17 December 1998 (1998-12-17) figures 3-5 ----- -/--	1		
<table style="width: 100%; border: none;"> <tr> <td style="width: 50%; border: none;"><input checked="" type="checkbox"/> Further documents are listed in the continuation of Box C.</td> <td style="width: 50%; border: none;"><input checked="" type="checkbox"/> See patent family annex.</td> </tr> </table>			<input checked="" type="checkbox"/> Further documents are listed in the continuation of Box C.	<input checked="" type="checkbox"/> See patent family annex.
<input checked="" type="checkbox"/> Further documents are listed in the continuation of Box C.	<input checked="" type="checkbox"/> See patent family annex.			
* Special categories of cited documents :				
"A" document defining the general state of the art which is not considered to be of particular relevance "E" earlier application or patent but published on or after the international filing date "L" document which may throw doubts on priority claim(s) or which is cited to establish the publication date of another citation or other special reason (as specified) "O" document referring to an oral disclosure, use, exhibition or other means "P" document published prior to the international filing date but later than the priority date claimed	"T" later document published after the international filing date or priority date and not in conflict with the application but cited to understand the principle or theory underlying the invention "X" document of particular relevance; the claimed invention cannot be considered novel or cannot be considered to involve an inventive step when the document is taken alone "Y" document of particular relevance; the claimed invention cannot be considered to involve an inventive step when the document is combined with one or more other such documents, such combination being obvious to a person skilled in the art "&" document member of the same patent family			
Date of the actual completion of the international search	Date of mailing of the international search report			
13 November 2013	21/11/2013			
Name and mailing address of the ISA/ European Patent Office, P.B. 5818 Patentlaan 2 NL - 2280 HV Rijswijk Tel. (+31-70) 340-2040, Fax: (+31-70) 340-3016	Authorized officer Coniglio, Carlo			

INTERNATIONAL SEARCH REPORT

International application No

PCT/CZ2013/000077

C(Continuation). DOCUMENTS CONSIDERED TO BE RELEVANT

Category*	Citation of document, with indication, where appropriate, of the relevant passages	Relevant to claim No.
A	US 2004/261731 A1 (FATHOLLAHI HOJJAT [IR]) 30 December 2004 (2004-12-30) claim 2 -----	1

INTERNATIONAL SEARCH REPORT

Information on patent family members

International application No

PCT/CZ2013/000077

Patent document cited in search report	Publication date	Patent family member(s)	Publication date
US 2004216703	A1	04-11-2004	AU 9767898 A 31-05-1999
			CA 2309669 A1 20-05-1999
			CN 1278888 A 03-01-2001
			EP 1030959 A1 30-08-2000
			JP 2001522962 A 20-11-2001
			NZ 329166 A 28-05-1999
			TW 390935 B 21-05-2000
			US 2004216703 A1 04-11-2004
			WO 9924696 A1 20-05-1999

US 6928965	B2	16-08-2005	AT 286203 T 15-01-2005
			AU 2002340887 B2 03-07-2008
			CA 2460162 A1 27-03-2003
			CN 1553988 A 08-12-2004
			DE 10145478 A1 28-05-2003
			EP 1427925 A1 16-06-2004
			JP 3943078 B2 11-07-2007
			JP 2005503512 A 03-02-2005
			RU 2293186 C2 10-02-2007
			US 2004216702 A1 04-11-2004
WO 03025369 A1 27-03-2003			

DE 3417342	A1	21-11-1985	NONE

WO 9857036	A1	17-12-1998	AU 8003898 A 30-12-1998
			WO 9857036 A1 17-12-1998

US 2004261731	A1	30-12-2004	NONE
